

OPERATION MANUAL

AC VOLTMETER

MODEL 1831B / 1851B

KIKUSUI ELECTRONICS CORPORATION, JAPAN

79.8.16

794212

# Power Requirements of this Product

Power requirements of this product have been changed and the relevant sections of the Operation Manual should be revised accordingly.

(Revision should be applied to items indicated by a check mark )

Input voltage

The input voltage of this product is \_\_\_\_\_ VAC,  
and the voltage range is \_\_\_\_\_ to \_\_\_\_\_ VAC. Use the product within this range only.

Input fuse

The rating of this product's input fuse is \_\_\_\_\_A, \_\_\_\_\_VAC, and \_\_\_\_\_.

**WARNING**

- To avoid electrical shock, always disconnect the AC power cable or turn off the switch on the switchboard before attempting to check or replace the fuse.
- Use a fuse element having a shape, rating, and characteristics suitable for this product. The use of a fuse with a different rating or one that short circuits the fuse holder may result in fire, electric shock, or irreparable damage.

AC power cable

The product is provided with AC power cables described below. If the cable has no power plug, attach a power plug or crimp-style terminals to the cable in accordance with the wire colors specified in the drawing.

**WARNING**

- The attachment of a power plug or crimp-style terminals must be carried out by qualified personnel.

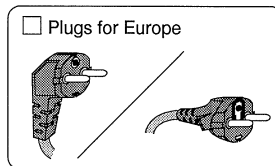
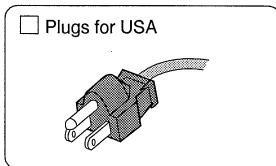
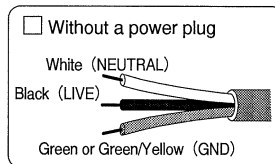
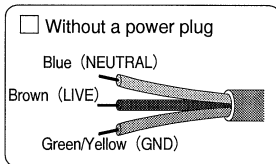

Provided by Kikusui agents

Kikusui agents can provide you with suitable AC power cable.  
For further information, contact your Kikusui agent.

Another Cable \_\_\_\_\_

TABLE OF CONTENTS

	<u>PAGE</u>
1. GENERAL .....	1
2. SPECIFICATION .....	2
3. OPERATION INSTRUCTIONS .....	5
3.1 Explanation of Front and Rear Panels .....	5
3.2 Preparations for Measurement .....	9
3.3 AC Voltage Measurement .....	9
3.4 AC Current Measurement .....	11
3.5 Use as an Output Meter .....	12
3.6 Waveform Errors .....	12
3.7 How to Use the Decibel Chart .....	13
4. OPERATING PRINCIPLE .....	18
4.1 Input Circuit .....	19
4.2 Preamplifier .....	19
4.3 Meter Driver .....	20
4.4 Output Circuit .....	20
4.5 Power Supply .....	21
5. MAINTENANCE .....	22
5.1 Inspection of Internal Components .....	22
5.2 Adjustment and Calibration .....	23
5.3 Troubleshooting .....	24
5.4 AC Line Voltage Modification .....	26
* Decibel conversion chart	
* Decibel addition chart	

## 1. GENERAL

Model 1831B/1851B AC Voltmeter is identical except their measuring ranges. This operation manual explains Model 1831B primarily, giving difference alone of Model 1851B being enclosed in [ ] .

The 1831B/1851B is a high-sensitivity 2-pointer electronic AC voltmeter which indicates two signals at the same time. The voltmeter is made of solid-state electronics, consume less power, and compact and light. It indicates the mean value of the measured signal.

The measuring range selection system is very convenient. When the red button on the knob is pushed-in and locked, both CH1 (INPUT 1) and CH2 (INPUT 2) can be switched at the same time in gang. When the button is pulled-out and unlocked, CH1 and CH2 can be switched mutually independently. It also is possible to switch CH1 and CH2 at the same time with a certain level difference.

The AC Voltmeter consists of an impedance converter with high input impedance, a voltage divider, a preamplifier, an indicator circuit, an output circuit and a constant voltage circuit for each of CH1 and CH2 mutually independently. The ground lines of the circuits are floated from the chassis ground and casing ground.

The measuring range is  $30 \mu\text{V} \sim 100 \text{ V rms}$  ( $-90 \sim +42 \text{ dB}$ ) [ $50 \mu\text{V} \sim 150 \text{ V rms}$  ( $-90 \sim +46 \text{ dB}$ )] divided into 12 sub-ranges in 10-dB steps. The scales are graduated in equal divisions in r.m.s. value of sinusoidal wave. The measuring frequency range is  $10 \text{ Hz} \sim 500 \text{ kHz}$ .

The output terminals of CH1 and CH2 provide AC output voltages of approximately 1 V [approximately 1.5 V] at full scale. Thus, the AC voltmeter can be used also as a monitor or a preamplifier.

## 2. SPECIFICATIONS

**Nomenclature:** AC Voltmeter

**Model No.:** 1831B/1851B

**Indicating meter:** 2-pointer type, dual scales in different colors, 1 mA FS for both scales

**Scale values:** r.m.s. value of sinusoidal wave, and dBm value with 1 mW 600  $\Omega$  as reference.  
dBv value with 1 V as 0 dB.

**Input terminals:** UHF-type receptacle and GND terminal  
19 mm (3/4") spacing

**Input resistance:** 1 M $\Omega$   $\pm$ 3%, for each range

**Input capacitance:** 40 pF or less, for each range

**Maximum allowable input voltages**

300  $\mu$ V ~ 100 mV [ 500  $\mu$ V ~ 150 mV ] ranges

AC component: 50 V in rms value,  $\pm$ 70 V in peak value  
DC component:  $\pm$ 400 V

300 mV ~ 100 V [ 500 mV ~ 150 V ] ranges

AC component: 100 V [ 150 V ] in rms value,  
 $\pm$ 150 V [  $\pm$ 250 V ] in peak value  
DC component:  $\pm$ 400 V

**Ranges:** 12 ranges

**RMS scale:** 300  $\mu$ V /1/3/10/30/100/300 mV and 1/3/10/30/100 V  
[ 500  $\mu$ V /1.5/5/15/50/150/500 mV and 1.5/5/15/50/150 V ]

**dBv, dB scale:** -70/-60/-50/-40/-30/-20/-10 and 0/10/20/30/40 dB

794215

Accuracy:  $\pm 3\%$  of full scale at 1 kHz

Stability: Better than 0.5% of full scale for  $\pm 10\%$  variation of power line voltage

Operating ambient temperature range:  $5^{\circ}\text{C} \sim 35^{\circ}\text{C}$  ( $41^{\circ}\text{F} \sim 95^{\circ}\text{F}$ )

Operating ambient humidity range: Up to 85% RH

Temperature coefficient: 0.04%/ $^{\circ}\text{C}$  (for reference only)

Frequency characteristics: 10 Hz - 500 kHz ...  $\pm 5\%$  with reference to 1 kHz  
 20 Hz - 200 kHz ...  $\pm 3\%$  with reference to 1 kHz

Noise level: Less than 3% of full scale when input terminals are shorted.

Output terminals: 5-way binding posts, 19 mm ( $3/4$ " ) spacing

Output voltage: 1 [ 1.5 V ]<sub>rms</sub>  $\pm 5\%$  at full scale of "1.0" [ "15" ] scale

Distortion factor: Less than 2%, at full scale and at 1 kHz

Frequency response: With input resistor 10 M $\Omega$  and input capacitor 30 pF connected to output terminal,  
 10 Hz - 200 kHz  $\begin{matrix} +1 \text{ dB} \\ -3 \text{ dB} \end{matrix}$

Power requirements: 100/110/117/220/230/240 V (selectable by internal tap connection), 50/60 Hz, approx. 6.0 VA

Dimensions: 134 (W) x 164 (H) x 270 (D) mm  
(5.28 (W) x 6.46 (H) x 10.6 (D) in.)

Maximum dimensions: 140 (W) x 190 (H) x 340 (D) mm  
(5.51 (W) x 7.48 (H) x 13.4 (D) in.)

Weight: Approx. 4.3 kg (9.5 lb.)

Accessories: Type 941B terminal adaptors ..... 2  
Operation manual ..... 1 copy

### 3. OPERATION INSTRUCTIONS

#### 3.1 Explanation of Front and Rear Panels

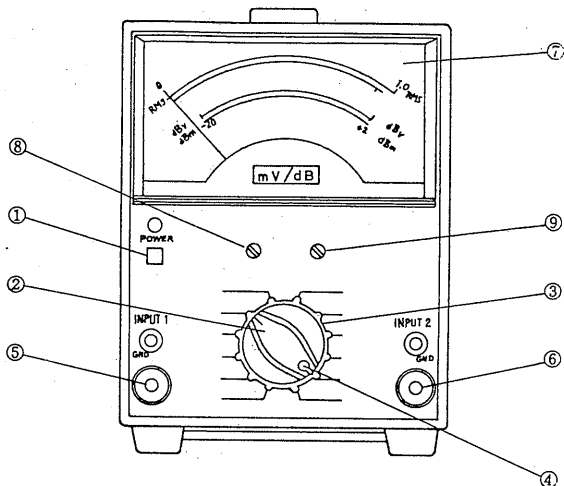

Fig. 3-1

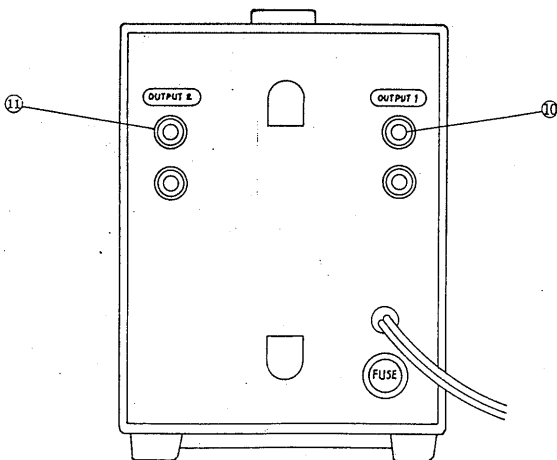

Fig. 3-2



- (1) POWER            The pushbutton switch for meter power ON-OFF. The depressed and locked position is for ON. As the button is pushed again, it pops out into the OFF position. The meter pointers may deflect irregularly for approximately 10 sec after the power is turned ON, but this is not an abnormal indication.
- (2) INPUT 1 (CH1)    The knob located in the center of front panel, range switch: for selection of 12 ranges covering a total range of 300  $\mu$ V ~ 100 V [ 500  $\mu$ V ~ 150 V ].
- (3) INPUT 2 (CH2)    The black figures are for V values. range switch: The blue figures are for dB values. The inner arrow knob is for range selection of INPUT 1 and the outer round knob is for that of INPUT 2.
- (4) Range switch     The red button on the inner knob. The depressed lock button: and locked position is for simultaneous switching of INPUT 1 and INPUT 2 in gang. The unlocked and popped out position is for switching of individual channels.
- (5) INPUT 1            The terminal to which the signal to be measured terminal: is applied. Consists of a UHF-type receptacle and a GND binding-post terminal. Connection can be conveniently made with a UHF-type
- (6) INPUT 2            (5/8"-24) or M-type (16P-1P) plug or with terminal: a standard 2-pin banana plug (spacing: 3/4" = 19 mm).

Connection can be made also with a banana plug for to the center conductor of the receptacle. When "Kikusui 941B Terminal Adaptor" is

inserted, connection can be made with a banana plug, spade lug, alligator clip, 2-mm tip or a wire of smaller than 2 mm as is the case for the GND terminal.

The outer conductor and GND terminal are electrically connected to the meter panel and chassis.

(7) Indicating meter:

The indicating meter has two pointers -- red pointer for INPUT 1 and black pointer for INPUT 2. It has four scales as follows:

1) "1.0" [ "15" ] scale:

For 1/10/100 mV and 1/10/100 V  
[ 1.5/15/150 mV and 1.5/15/150 V ] ranges.  
Scale "1.0" [ "15" ] at 1 [ 1.5 ] mV  
range is for 1.0 [ 1.5 ] mV and at 100  
[ 150 ] V range is for 100 [ 150 ] V.

2) "3" [ "5" ] scale:

For 300  $\mu$ V /3/30/300 mV and 3/30 V  
[ 500  $\mu$ V /5/50/500 mV and 5/50 V ] ranges.  
Meanings of scale figures are the same  
with those of the case of "1.0" [ "15" ]  
scale.

3) "dBm" scale:

For measurement in dBm value with  
reference to 1 mW 600  $\Omega$ . The same scale  
is used for all of 12 ranges of -70 to  
+40 dBm.

4) "dBv" scale:

For measurement in dBv value with reference  
to 1 V. The same scale is used for all of  
12 ranges of -70 to +40 dB.

(8) (9) ZERO

adjustment:

The red screw (8) is for mechanical zero adjustment of INPUT 1 pointer (red) of indicating meter; the black screw (9) is for mechanical zero adjustment of INPUT 2 pointer (black).

(10) (11) OUTPUT

terminals:

The output terminals on the rear panel, which provide output signals when the meter is used as an amplifier. OUTPUT terminals (10) provide the output for INPUT 1 and OUTPUT terminals (11) provide that for INPUT 2. The black ones are ground terminals.

Connection can be most conveniently made with 2-pin banana plugs connected to a coaxial cable. Connection can also be made, as is the case for "Kikusui Type 941B" Terminal Adaptor, with banana plugs, spade lugs, alligator clips, 2-mm (0.079 in.) tips, or wires of 2 mm (0.079 in.) or less.

### 3.2 Preparations for Measurement

- 1) Turn OFF the POWER switch at the left-hand side on the front panel.
- 2) Check that the pointers are accurately in the center of the zero scale position. If they are not in this position, adjust them accurately to this position. If the meter power has been turned ON, turn it OFF and wait for approximately 5 minutes so that the pointers are stabilized in positions close to the zero position and then perform the zero adjustment.
- 3) Connect the meter power plug to an AC line power outlet of 100 V (or 110/117/220/230/240 V in conformity with internal tap selection) 50/60 Hz AC.
- 4) Set the range selector in the 100 V [ 150 V ] position.
- 5) Turn ON the POWER switch. The Power pilot lamp will light indicating that the meter power is turned on. The meter pointers may deflect irregularly for about 10 seconds when the switch is turned ON or OFF, but this is not an abnormal indication.
- 6) When the pointers are stabilized, the meter is ready for measurement.

### 3.3 AC Voltage Measurement

- 1) When the measured signal level is low or the measured signal source impedance is high, the input line is susceptible to external noise. To guard against noise, shielded wires or a coaxial cable should be used depending on the noise frequency. When the measured signal is a low frequency and a higher level and its source impedance is low, measurement can be conveniently

794222

performed using the 941B Terminal Adaptor which is supplied as an accessory of the meter.

Note: For 300  $\mu$ V and 1 mV [ 500  $\mu$ V and 1.5 mV ] range measurement, the use of shielded wires or a coaxial cable for the input line is recommended.

- 2) In order to prevent overload to the meter, start measuring with the highest range and gradually lower the range observing the pointer deflection.
- 3) Use the "1.0, 3" [ "15, 50" ] scales of the indicating meter. The scale values are shown in Table 3-1.

Table 3-1

Range			Scale		Scale factor		Unit	Gain
300 $\mu$ V	500 $\mu$ V	-70dB	3	50	x100	x10	$\mu$ V	70dB
1mV	1.5mV	-60dB	1.0	15	x1	x0.1	mV	60dB
3mV	5mV	-50dB	3	50	x1	x0.1	mV	50dB
10mV	15mV	-40dB	1.0	15	x10	x1	mV	40dB
30mV	50mV	-30dB	3	50	x10	x1	mV	30dB
100mV	150mV	-20dB	1.0	15	x100	x10	mV	20dB
300mV	500mV	-10dB	3	50	x100	x10	mV	10dB
1 V	1.5 V	0dB	1.0	15	x1	x0.1	V	0dB
3 V	5 V	10dB	3	50	x1	x0.1	V	-10dB
10 V	15 V	20dB	1.0	15	x10	x1	V	-20dB
30 V	50 V	30dB	3	50	x10	x1	V	-30dB
100 V	150 V	40dB	1.0	15	x100	x10	V	-40dB

- 4) To measure the input voltage in dBm value with reference to 1 mW 600 $\Omega$ , use the common dBm scale and determine the value as follows:

794223

The "0" position in the center position of the dBm scale represents the level of each range. Add the dBm value of the range to the dBm value indicated by the pointer, to determine the dBm value of the measured signal.

Example 1: When the pointer indication is 2 (dBm) at the "30 dB (30 V) [ (50) ] range," determine the signal level as

$$2 + 30 = 32 \text{ dBm}$$

Example 2: When the pointer indication is 1 (dBm) at the "-20 dB (100 mV) [ (150 mV) ] range," determine the signal level as

$$1 + (-20) = 1 - 20 = -19 \text{ dBm}$$

#### 3.4 AC Current Measurement

To measure a AC current (I) with this meter, feed the current through a non-inductive resistor of a known resistance (R) and measure the voltage drop (E) developed across the resistor. The current can be determined as  $I = E/R$ . In this case, note that the "-" input terminal of the meter must be grounded.

Example: Measure the heater current of a vacuum tube (nominal 6.3 V, 0.3 A).

Assume that a non-inductive resistor of 0.1  $\Omega$  was connected as shown in Fig. 3-3 and the meter reading was 29 mV. The current can be determined as follows:

$$I = \frac{29 \times 10^{-3}}{0.1} = 290 \times 10^{-3} \text{ (A)} = 290 \text{ (mA)}$$

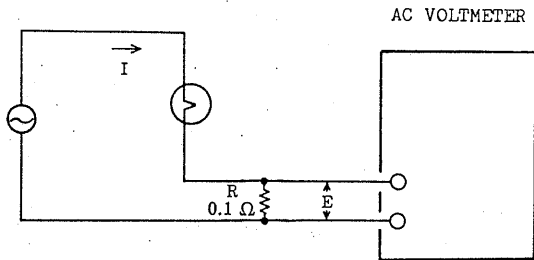

Fig. 3-3

### 3.5 Use as an Output Meter

Measuring the voltage ( $E$ ) developed across a certain impedance ( $X$ ), the apparent power ( $VA$ ) in the impedance ( $X$ ) can be determined as  $VA = E^2/X$ . Assuming that the impedance ( $X$ ) is a pure resistance ( $R$ ), the power ( $P$ ) consumed in the resistance ( $R$ ) is calculated as follows:

$$P = E^2/R$$

Since the meter scale is graduated in dBm value, the power can be directly read in the dB value when the resistance ( $R$ ) is 600 Ω. If the load resistance is within a range of 1 Ω to 10 KΩ, the power can be read in decibels by adding the value obtained from the decibel conversion charts, Figs 3-4 and 3-5.

### 3.6 Waveform Errors

This meter is a "mean-value indicating" AC voltmeter which indicates a value proportional to the mean value of the measured voltage. The meter scale are calibrated in the r.m.s. value of a sinusoidal wave. If the measured signal waveform is distorted, the meter does not indicate the correct r.m.s. value but errors

794225

are introduced. Rates of errors caused by waveform distortions are shown in Table 3-2.

Measured voltage	r.m.s. value (%)	Meter indication (%)
Amplitude 100% fundamental wave	100	100
100% fundamental wave +10% 2nd harmonic wave	100.5	100
100% fundamental wave +20% 2nd harmonic wave	102	100 - 102
100% fundamental wave +50% 2nd harmonic wave	112	100 - 110
100% fundamental wave +10% 3rd harmonic wave	100.3	95 - 104
100% fundamental wave +20% 3rd harmonic wave	102	94 - 108
100% fundamental wave +50% 3rd harmonic wave	112	90 - 116

### 3.7 How to Use the Decibel Chart

#### 1) Decibel

Bel (B) is a unit of measure for comparing two power levels in terms of the common logarithm with 10 as its base.

Decibel (dB) is one-tenth of Bel (B) as indicated with the affix "d" and it is expressed as follows:

$$\text{dB} = 10 \log_{10} \frac{P_2}{P_1}$$

In other words, the dB value indicates the ratio of power  $P_2$  with respect to power  $P_1$  in terms of the common logarithm multiplied by a factor of 10.



$$\text{dB} = 20 \log_{10} \frac{E_2}{E_1} \quad \text{or} \quad 20 \log_{10} \frac{I_2}{I_1}$$

Though decibel initially was meant for representing the ratio of power levels, it since long ago has become to be used in a broader sense to indicate a ratio between two numbers in terms of common logarithm.

For an example, when the input voltage of an amplifier is 10 mV and its output is 10 V, the gain is  $10\text{V}/10\text{mV} = 1000$ . In terms of decibel, the amplifier gain is expressed as follows:

$$\text{Gain} = 20 \log_{10} \frac{10 \text{ V}}{10 \text{ mV}} = 60 \text{ (dB)}$$

For a standard RF signal generator for another example, its output voltage is given in terms of dB value with reference to 1  $\mu\text{V}$ . When the output voltage is 10 mV, it is expressed as follows:

$$10 \text{ mV} = 20 \log \frac{10 \text{ mV}}{1 \mu\text{V}} = 80 \text{ (dB)}$$

When given in a dB value, the reference value or the 0 dB value should be indicated. In the case of the signal generator of the above example, the output voltage should be indicated as 10 mV = 80 dB (1  $\mu\text{V}$  = 0 dB) with the 0 dB value given enclosed in parentheses.

## 2) dBm, dBv

Term dBm means dB(mW). It represents a power ratio with reference to 1 mW as 0 dB. In general the term is for a case that the impedance of the power measuring point is 600  $\Omega$  or the term signifies dB (mW 600 $\Omega$ ).

When the power and impedance are specified as above, decibel can represent voltage and current as well as power. Term dBm is given in reference to the values as follows:

0 dBm = 1 mW or 0.775 V,  
or 1.291 mA

Term dBv represents a voltage ratio with reference to 1 V as 0 dB. This term is widely used in audio engineering as it provides a convenient means of voltage level conversion.

Since the decibel scales of the AC Voltmeter are graduated in such dBm and dBv values, the indicated value must be converted when other value than "1mW, 600Ω" or "1V" is used for the reference value. Due to the nature of the logarithm, correction can be accomplished by adding a certain value to the meter reading. Refer to Figs. 3-4 and 3-5 for the correction values.

### 3) Decibel Conversion Chart

Fig. 3-4 shows a chart for converting ratios into decibel values. Decibel values are different according to whether the ratio is of power (or equivalent) or it is of voltage or current.

Example 1: What dB is 5 mW with reference to 1 mW?

Since the ratio is of power, the left-hand scale must be used. Calculating  $5\text{mW}/1\text{mW} = 5$ , the dB value is known to be 7 dB (mW) as indicated by the dotted line in the illustration.

Example 2: What are 50 mW and 500 mW in dB values with reference to 1 mW?

When the ratio is larger than 0.1 time or higher than 10, decibel values must be calculated through addition or subtraction using the relationship shown in Fig. 3-4.

794228

$$50 \text{ mW} = 5 \text{ mW} \times 10 = 7 + 10 = 17 \text{ dB}$$

$$500 \text{ mW} = 5 \text{ mW} \times 100 = 7 + 20 = 27 \text{ dB}$$

Table 3-3

Ratio		Decibel	
		Power ratio	Voltage or current ratio
10,000	$= 1 \times 10^4$	40 dB	80 dB
1,000	$= 1 \times 10^3$	30 dB	60 dB
100	$= 1 \times 10^2$	20 dB	40 dB
10	$= 1 \times 10^1$	10 dB	20 dB
1	$= 1 \times 10^0$	0 dB	0 dB
0.1	$= 1 \times 10^{-1}$	-10 dB	-20 dB
0.01	$= 1 \times 10^{-2}$	-20 dB	-40 dB
0.001	$= 1 \times 10^{-3}$	-30 dB	-60 dB
0.0001	$= 1 \times 10^{-4}$	-40 dB	-80 dB

Example 3: What is 15 mV in dB(V) value?

Since this decibel is referenced to 1 V, calculate at first as  $15\text{mV}/1\text{V} = 0.015$ . Next, using the voltage/current scale, calculate as  $0.015 = 1.5 \times 0.01 = 3.5 + (-40) = -36.5 \text{ dB(V)}$  or in the reverse as  $1\text{V}/15\text{mV} = 66.7$ .

$$66.7 = 6.67 \times 10 \quad 16.5 + 20 = 36.5 \text{ dB(V)}$$

#### 4) Decibel Addition Chart

Fig. 3-5 shows an addition chart which is used when calculating the power from the dBm value determined by this meter.

Example 1: The voltage across the voice coil of a speaker of  $8 \Omega$  was measured with this meter and the indication was  $-4.8 \text{ dBm}$ . What was the power (apparent power) being sent to the speaker?

794229

Referring to Fig. 3-5, the value to be added is determined to be +18.8 as indicated with the dotted line in Fig. 3-5. The power level can be known by adding this value to the indicated value as follows:

$$\text{dB (mW, } 8\Omega) = -4.8 + 18.8 = +14$$

The value of 14 dB (mW, 8 $\Omega$ ) can be converted referring to Fig. 3-4 as 14 dB (mW, 8 $\Omega$ )  $\rightarrow$  25 mW.

Example 2: What voltage (V) is required to feed a power of 1 W to a load of 10 k $\Omega$ .

Since 1 W is 1000 mW or 30 dB (mW), a voltage which will give 30 dB (mW, 10 k $\Omega$ ) should be calculated. Referring to Fig. 3-5, the value to be added for 600  $\Omega$   $\rightarrow$  10 k $\Omega$  is known to be -12.2. Therefore, the indication of this meter should be  $30 - (-12.2) = 42.2$  on the dB (mW, 600  $\Omega$ ) scale. The required voltage is such that it causes a deflection of  $42.2 - 40 = 2.2$  dBm on the 40 dB (0 - 100 V) [(0 - 150 V)] range. Thus, the voltage is calculated to be 42.2 dBm = 100 V.

#### 4. OPERATING PRINCIPLE

The 1831B/1851B AC Voltmeter consists of an input circuit, preamplifier, meter driver, and power supply for each of two channels of INPUT 1 and INPUT 2. The ground line of each circuit is connected through a resistor to the ground line of the power supply and chassis. Thus, the ground lines of INPUT 1 and INPUT 2 are mutually isolated and also floated from the ground of chassis and casing through resistors. The parts numbers not enclosed in the parentheses are for INPUT 1 and those enclosed in the parentheseses are for INPUT 2.

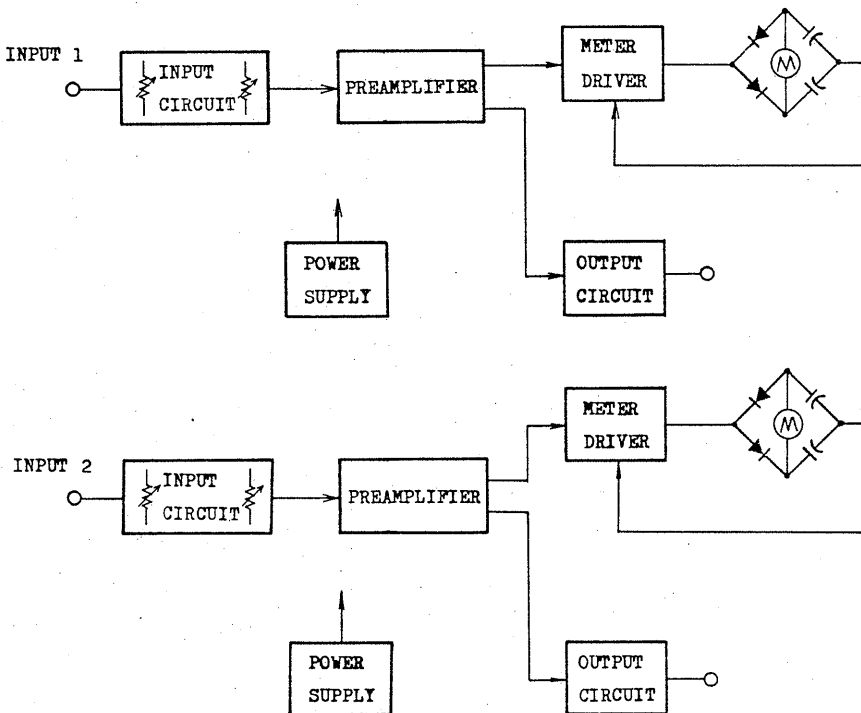

Fig. 4-1

794231

#### 4.1 Input Circuit

The input circuit consists of a 1st-stage attenuator (0/60 dB), an impedance converter, and a 2nd-stage 10-dB-step 6-range attenuator (0/10/20/30/40/50 dB) as shown in Fig. 4-2.

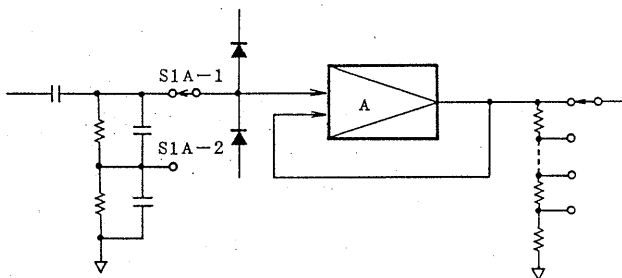

Fig. 4-2

The input signal is fed to S1A-1 when the range switch is in a position of 300  $\mu$ V ~ 100 mV [ 500  $\mu$ V ~ 150 mV ] or through S1A-2 when the range switch is in a position of 300 mV ~ 100 V [ 500 mV ~ 150 V ]. After being attenuated as required, the input signal is fed to the impedance converter which has transistors Q101 and Q102 (Q201 and Q202) with FET for the initial stage and which provides a high input impedance and a low output impedance. Then the signal is fed to the 2nd-stage signal attenuator which attenuates the signal level to approximately 300  $\mu$ V [ approx. 500  $\mu$ V ]. Diodes CR101 and CR102 (CR201 and CR202) are for protection against overvoltage input.

#### 4.2 Preamplifier

The preamplifier amplifies the low level signal received from the input circuit. It is a negative feedback amplifier consisting of three transistors.

794232

#### 4.3 Meter Driver

The indicating meter driver circuit has transistors Q405 and Q406 (Q505 and Q506). The signal is fed from the collector of Q405 (Q505) to the emitter of Q406 (Q506) through a current feedback circuit.

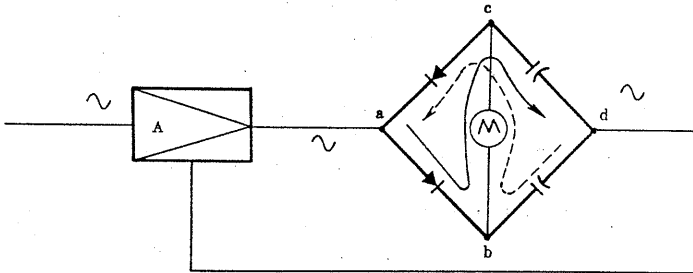

Fig. 4-3

Due to the above, the diode operates with a current almost constant, thereby improving its non-linearity and providing a linear scale. Fig. 4-3 illustrates this function. The current for the positive cycles of the amplifier output voltage flows  $a \rightarrow b \rightarrow c \rightarrow d$  and that for the negative cycles flows  $d \rightarrow b \rightarrow c \rightarrow a$ . The indicating meter deflects representing the mean value of this current.

#### 4.4 Output Circuit

The collector voltage of transistor Q402 (Q502) of the preamplifier is amplified by transistor Q404 (Q504) and the amplified signal is delivered for an external use. The output terminal voltage is approximately 1 V [approximately 1.5 V] rms when the indicating meter is deflected to the full scale.

794233

#### 4.5 Power Supply

The power supply circuit has two constant-voltage circuits for +11 V supply and +25 V supply. The +25 V constant-voltage circuit has zener diode CR303 (CR308) which provides the reference voltage, transistor Q302 (Q304) which amplifies the error voltage, and transistor Q301 (Q303) which controls the voltage in series in order to provide the constant voltage supply. The +11 V constant-voltage supply is derived from the reference voltage. Diode CR304 (CR309) is for circuit protection.



## 5. MAINTENANCE

### 5.1 Inspection of Internal Components

To gain access to the internal components, remove the top cover after removing the two clamping-screws on the top and other two clamping-screws at each of right and left side and remove the bottom cover after removing the four clamping-screws at the bottom. The layouts of components are shown in Figs. 5.1 and 5.2.

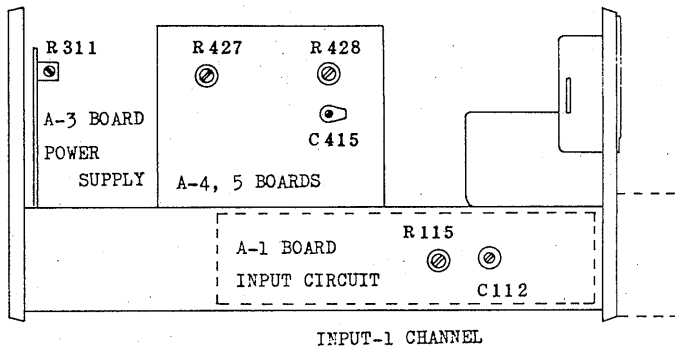

Fig. 5-1

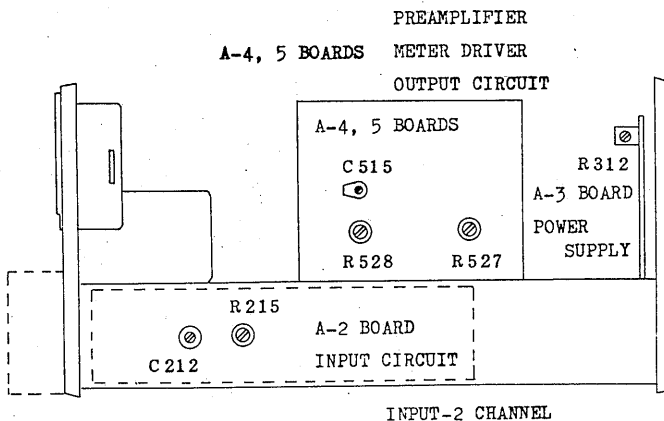

Fig. 5-2

## 5.2 Adjustment and Calibration

When the meter is found that it does not satisfies the specification after a long period of use or after repair, adjust and calibrate the meter as follows:

### (1) Adjustment of Constant-voltage Circuit

Connect a DC voltmeter between the emitter of transistor Q301 (Q303) of power supply circuit and the ground. So adjust potentiometer R311 (R312) that the voltmeter reads +25 V. (The items enclosed in the parentheses are for the INPUT-2 channel.)

### (2) Calibration for High and Low Frequency Ranges (Preamplifier)

Before calibrating the meter, perform ZERO adjustment of the meter as explained in Par. 3.2 (2). Then, proceed as follows:

Set the RANGE switch in the 10 mV [ 15 mV ] position. Apply a calibration voltage (a sinusoidal waveform of low distortion) of 10 mV [ 15 mV ] 1 kHz to the input terminal. So adjust potentiometer R428 (R528) of the preamplifier that the meter pointer deflects accurately to the full scale position.

Next, set the calibration signal frequency at 500 kHz. Adjust trimmer capacitor C415 (C515) in the same manner as above.

### (3) Adjustment of 1st-stage Attenuator

Set the RANGE switch in the 300 mV [ 500 mV ] position. Apply a calibration signal of 300 mV [ 500 mV ] 1 kHz to the input terminal. So adjust potentiometer R115 (R215) of the attenuator that the meter pointer deflects to the full scale position.

Next, set the calibration signal frequency at 500 kHz. Adjust trimmer capacitor C112 C212 in the same manner as above.

Repeat alternately the above adjustment procedures at 1 kHz and 500 kHz for several times or until both conditions are satisfied at the same time.

#### (4) Adjustment of Output Amplifier

Set the RANGE switch in the 1 V [ 1.5 V ] position. Apply a calibration signal of 1 V [ 1.5 V ] 1 kHz to the input terminal. So adjust potentiometer R427 (R527) that the voltage delivered to the output terminal is made 1 V [ 1.5 V ].

Note: Perform the above adjustments of (2) through (4) for both INPUT-1 channel (the red pointer) and INPUT-2 channel (the black pointer).

### 5.3 Troubleshooting

The meter is manufactured under stringent quality control and should be free of troubles. However, when it has failed due to aging or other cause, check it referring to the circuit voltage charts given in this section. The normal circuit voltages when no signal is applied to the meter are shown in Tables 5-1, 5-2, and 5-3. These voltages are as measured with reference to the ground using Kikusui Model 107B or 107C VOLT/OHM METER, the input impedance of which is 11 MΩ.

794237

(1) Impedance Converter (A-1 and A-2 boards)

Table 5-1

Transistor	Emitter (Source)	Base (Gate)	Collector (Drain)
Q101, Q201 2SK117	6.7 V		20.0 V
Q102, Q202 2SC372	6.0 V	6.6 V	25.0 V

(2) Preamplifier, Meter Driver, and Output Circuit (A-4, 5 boards)

Table 5-2

Transistor	Emitter	Base	Collector
Q401, Q501 2SC372			4.4 V
Q402, Q502 2SC372	5.5 V	6.1 V	10.4 V
Q403, Q503 2SA495	5.0 V	4.4 V	3.0 V
Q404, Q504 2SC945	9.8 V	10.4 V	20.2 V
Q405, Q505 2SC945			5.5 V
Q406, Q506 2SC945	4.8 V	5.5 V	11.2 V

(3) Power Supply (A-3 board)

Table 5-3

Semiconductor devices	Emitter (Cathode)	Base (Anode)	Collector
Q301, Q303 2SD381	25.0 V	25.7 V	41.5 V
Q302, Q304 2SC945	11 V	11.6 V	25.7 V
CR303, CR308 RD11E	11 V	0 V	
CR305, CR310 EQA01-07S	32.0 V	25.0 V	

#### 5.4 AC Line Voltage Modification

In order to be applicable to various AC line voltages, the primary winding of the power transformer is tapped for 110 V, 117 V, 220 V, 230 V and 240 V in addition to 100 V. To change the AC line voltage of the meter, remove the transformer cover and change the tap to the required one. The color coding of the taps is shown in Table 5-4.

Table 5-4

Tap wire color	Tap wire number	Voltage (V)
Black	0	0
Brown	1	100
Red	2	110
Orange	3	117
Yellow	4	220
Green	5	230
Blue	6	240

794239